

# Operator's Manual · Trim Master-MBWT5B



**⚠ WARNING: READ ENTIRE MANUAL BEFORE ATTEMPTING TO OPERATE MACHINE!**  
If incorrectly used this machine can cause severe injury. Those who use and maintain this machine should be trained in its proper use, warned of its dangers, and should read the entire manual before attempting to set up, operate, adjust, or service this machine.



The Engine Exhaust from this product contains chemicals known to the State of California to cause cancer, birth defects or other reproductive harm.

IMPORTANT: THIS UNIT IS EQUIPPED WITH AN INTERNAL COMBUSTION ENGINE AND SHOULD NOT BE USED ON OR NEAR ANY UNIMPROVED FOREST-COVERED, BRUSH-COVERED, OR GRASS-COVERED LAND UNLESS THE ENGINE'S EXHAUST SYSTEM IS EQUIPPED WITH A SPARK ARRESTER MEETING APPLICABLE LOCAL LAWS (IF ANY). IF A SPARK ARRESTER IS USED, IT SHOULD BE MAINTAINED IN EFFECTIVE WORKING ORDER BY THE OPERATOR.

IN THE STATE OF CALIFORNIA, A SPARK ARRESTER IS REQUIRED BY LAW (SECTION 4442 OF THE CALIFORNIA PUBLIC RESOURCES CODE). OTHER STATES MAY HAVE SIMILAR LAWS. FEDERAL LAWS APPLY ON FEDERAL LANDS. SEE YOUR AUTHORIZED SERVICE CENTER FOR A SPARK ARRESTER.

## Important Rules for Your Safety



Before operating this machine read all the instructions for safe operation, as well as, the instructions governing the engine and other components of this machine.

### TRAINING

- Read the Owner's Manual carefully. Be thoroughly familiar with the controls and the proper use of the equipment. Know how to stop the unit and disengage the controls quickly.
- Never allow children to operate the equipment. Never allow adults to operate the equipment without proper instruction.
- Operators should be mature enough to understand the dangers of the equipment.

### PREPARATION

- Thoroughly inspect the area where the trimmer is to be used and remove all foreign objects.
- Keep the area of operation clear of all persons, particularly small children and pets.
- Do not operate the equipment without wearing adequate outer garments.
- Wear footwear that will improve footing and provide adequate protection.
- Loose clothing may be caught by moving parts on the machine or by the surrounding environment and cause serious injury.
- Wear safety goggles to protect eyes from any debris or objects that may be thrown from the trimmer.
- Wear long pants, sturdy shoes and gloves to protect yourself from debris, sticks, rocks or other objects which could be thrown from trimmer.
- Handle fuel with care. It is highly flammable.
- Use only an approved fuel container.
- Never add fuel to a running engine or a hot engine.
- Fill fuel tank outdoors with extreme care. Never fill fuel tank indoors.
- Replace gasoline cap securely and clean up spilled fuel before starting.
- Never attempt to make any adjustments while the engine is running (except where specifically recommended by manufacturer).
- Do not operate trimmer until you are familiar with all controls and safety symbols.

### OPERATION

- Do not attempt to trim high slope areas. Move across the slope, not up and down.
- Avoid areas with heavy debris and rocks, since the objects could be thrown from the trimmer and cause serious injury.
- Trim only when the grass is dry. Wet grass can cause slipping.
- Exercise extreme caution when operating near or crossing gravel drives, walks or roads. Gravel can be thrown from the trimmer and cause injury.

- Stay alert for hidden hazards or traffic.
- Disengage trimmer head when crossing driveways or other rocky areas.
- Keep trimming area free of children and pets.
- Never operate the trimmer indoors where exhaust from engine can collect. It contains carbon monoxide which is a tasteless, odorless, poisonous gas.
- Operator should never place hands, feet, or any part of his body or clothing near any moving part of this trimmer.
- Never operate the trimmer without proper guards, plates, or other safety protective devices in place.
- Take all possible precautions when leaving the machine unattended. Stop the engine.
- Stop the engine when leaving the operating position.
- If the trimmer should start to vibrate abnormally, stop the engine and check immediately for the cause. Vibration is generally a warning of trouble.
- After striking a foreign object, stop the engine, remove the spark plug wire, and thoroughly inspect the trimmer for any damage. If damage has occurred repair the damage before restarting and operating the trimmer.
- Do not put hands or feet near or under rotating parts.
- Never operate the machine at high speeds on slippery surfaces. Look behind and use care when backing up.
- Do not run while using equipment.
- Equipment should only be used as it was intended. Misuse can cause serious injury.
- Operate equipment only in a well lit area. Do not use trimmer after dark without artificial light.
- Never operate equipment when under the influence of drugs, alcohol, or prescription drugs which could cause drowsiness or poor judgement.

### MAINTENANCE

- Keep machine in good working condition.
- Before cleaning, repairing, or inspecting the machine, shut off the engine and make certain all moving parts have stopped. Disconnect spark plug.
- Follow the recommendations for maintenance described in this manual and the engine literature.
- Keep engine and trimmer free from accumulations of grass, leaves, or excessive grease. An accumulation of these combustible materials may result in fire.
- Store gasoline only in an approved container.
- Never store machine with fuel in the fuel tank inside a building where open flame or spark are present. Allow engine to cool before storing in any enclosure.
- Frequently check all bolts and other connectors for proper tightness before operating the equipment.
- Replace safety decals as needed.

**ASSUMPTION OF RISK: THE OWNER AND/OR OPERATOR OF THIS TRIMMER ASSUMES ALL THE RISKS INCIDENT TO AND ARISING OUT OF THE OPERATION OF THIS MACHINE. BEFORE OPERATING THE TRIMMER, READ ALL THE INSTRUCTIONS GOVERNING THE ENGINE AND THE TRIMMER.**

## Assembly

1. Remove the Trimmer from the carton by cutting the box on all four corners and rolling it off the box base.
2. Remove owner's manuals and parts bag.
  - Parts bag includes a pair of safety glasses and an allen wrench.
3. Raise the handles (See figure 1).
  - Hold the handle with one hand and loosen handle knobs. Do not remove the knobs.
  - Raise the handle to the upright position.
  - Insure cables are not caught between the two handle parts.
  - Tighten the knobs on both sides of the handles.
  - Insure handle is secure.
4. Attach the recoil start rope handle to the rope guide.
5. Attach the upper safety shield.
  - Remove the loosened bolts on both sides of trimmer unibody frame (in front of the wheels).
  - Attach shield to trimmer frame.
5. Make sure all bolts are tight.

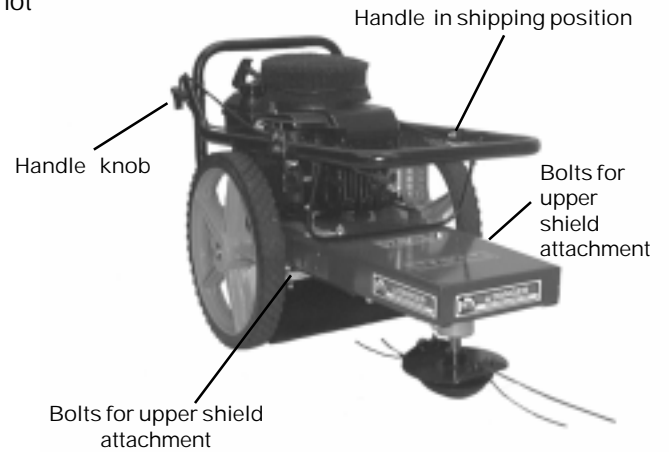

Figure 1

## Operation

### Before Starting Your Trim master . . .

1. Check your Trimmer. Be sure all bolts are tight. After several hours of operating and at periodic maintenance intervals, check all fasteners and tighten securely as required.
2. Check oil and fill according to the engine owner's manual (See Figure 2).



**WARNING : YOUR ENGINE IS SHIPPED WITHOUT OIL. YOU MUST FILL THE ENGINE WITH OIL BEFORE ATTEMPTING TO CRANK YOUR ENGINE.**

- Read Engine manual for full instructions and safety warnings.
- Place trimmer on level ground.
- Clean around oil fill area.
- Remove dipstick. Wipe with clean cloth.
- Reinsert dipstick and tighten. Remove dipstick and check.
- Oil should be at FULL level.
- If oil is required, add slowly. Recheck level.
- Tighten dipstick and clean around oil fill area before starting.

Figure 2

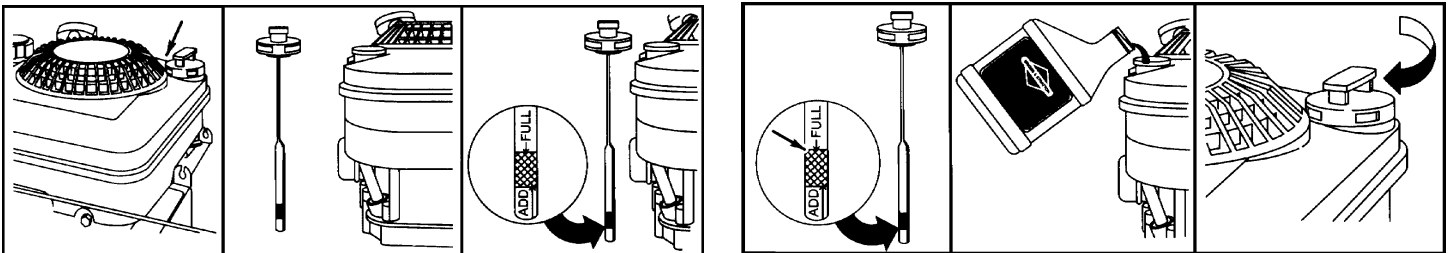

3. Fill engine with clean unleaded gasoline according to the engine owner's manual.



**WARNING: GASOLINE IS FLAMMABLE. USE CAUTION WHEN HANDLING OR STORING GASOLINE. NEVER FILL THE GAS TANK WHILE THE ENGINE IS RUNNING OR HOT. ALLOW THE ENGINE TO COOL BEFORE ADDING GAS. CLEAN ANY SPILLED GASOLINE.**

4. Remove all debris from guard, deck, muffler area, head cooling fins, and throttle controls.
5. Check the air cleaner element. Insure that the air filter is clean.
6. Familiarize yourself with all operating controls.



STRING TRIMMERS ARE PRONE TO DEBRIS BUILD-UP. CLEAN GRASS AND OTHER DEBRIS FROM GUARD, DECK, MUFFLER AREA, HEAD COOLING FINS, AND THROTTLE CONTROLS.



DO NOT ATTEMPT TO START OR OPERATE THIS TRIMMER UNTIL YOU ARE COMPLETELY FAMILIAR WITH LOCATION AND USE OF EACH CONTROL NECESSARY TO OPERATE THIS TRIMMER. YOU MUST KNOW HOW TO STOP THIS MACHINE BEFORE YOU START IT. EACH TIME PRIOR TO STARTING, CHECK THE THROTTLE ASSEMBLY TO INSURE IT IS WORKING PROPERLY.

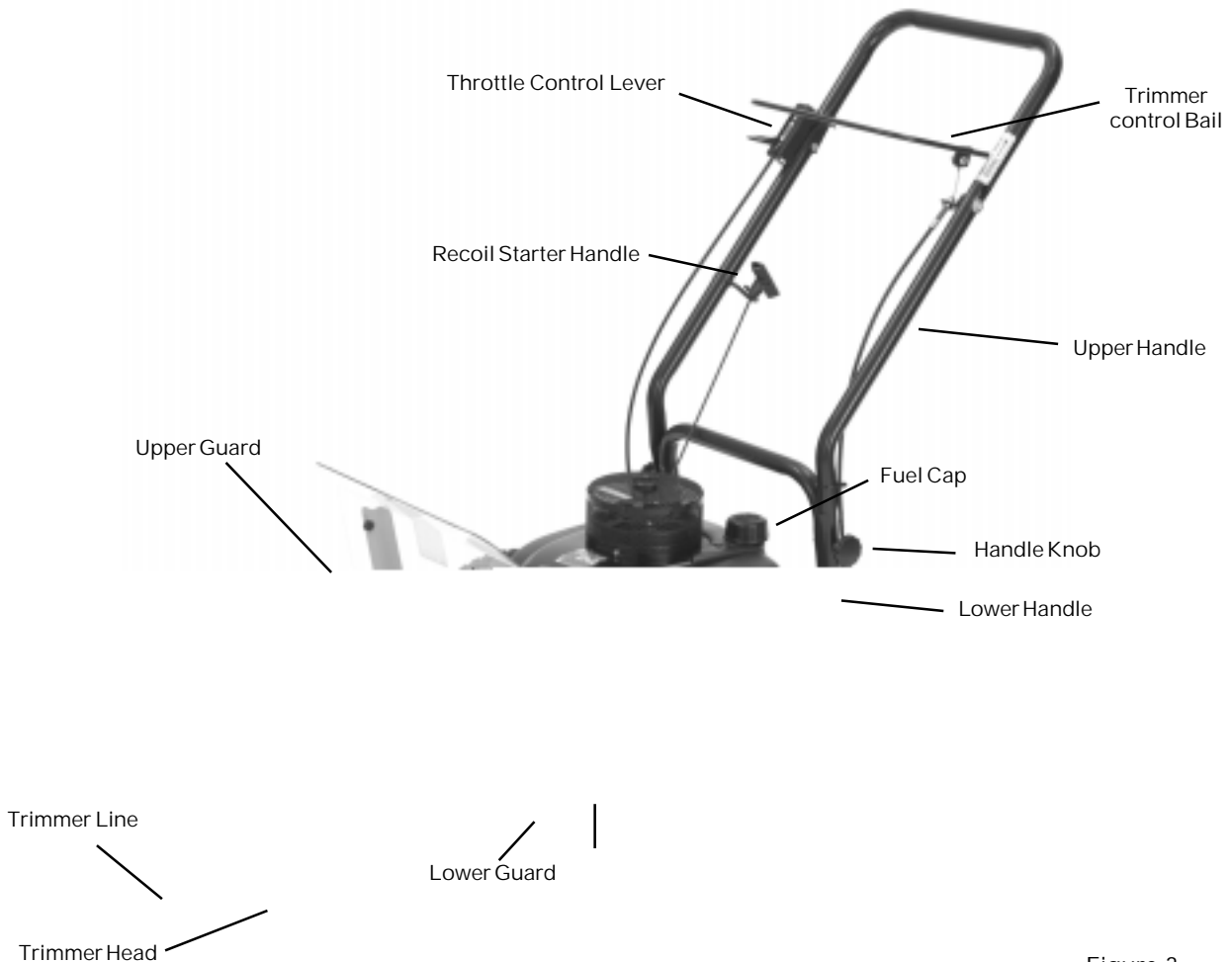

Figure 3

### Operating Controls

1. Trimmer Control Bail -- Controls the rotation of the trimmer head. To begin trimming pull the control bail towards the handle. To stop trimming release the control bail. It will return to the open position and disengage the trimmer head.

2. Throttle Control Lever -- Controls the speed of the engine or stops the engine. To stop the engine move the throttle back towards the operator to the stop or off position. The faster the engine runs, the faster the trimmer head will rotate.

3. Lower Guard -- The lower guard is a safety device that will help prevent debris from hitting the operator's feet and legs. Never operate this trimmer without the lower guard or if the lower guard is broken.

4. Upper Guard -- The upper guard is a safety device that will help prevent debris from hitting the operator's face and body. Never operate this trimmer without the upper guard or if the upper guard is broken.



NEVER OPERATE THE TRIMMER WITHOUT PROPER GUARDS, PLATES, OR OTHER SAFETY DEVICES IN PLACE. SERIOUS INJURY OR DEATH COULD RESULT.



EVEN THOUGH THIS TRIMMER IS EQUIPPED WITH SAFETY SHIELDS, IT IS POSSIBLE FOR DEBRIS TO BE THROWN FROM THE TRIMMER. WEAR SAFETY GLASSES AT ALL TIMES AND KEEP THE TRIMMING AREA CLEAR OF BY-STANDERS ESPECIALLY SMALL CHILDREN AND PETS.

## Starting the engine

1. Read engine owner's manual for complete starting instruction. Do not operate this trimmer without reading the engine owner's manual.
2. Move the throttle control lever forward to the START or FAST position.
3. Push primer bulb firmly 3 times before starting engine. Note: Priming is usually unnecessary when restarting a warm engine.
4. Grasp rope handle and pull slowly until resistance is felt. Then pull cord rapidly to overcome compression, prevent kickback and start engine.
5. Operate engine in the fast throttle position.

## Adjustments and Maintenance

### Trimmer Line

1. Your trimmer loses trimming efficiency when the trimmer line is used beyond half of original length.
2. For best performance use a heavy gauge (.155" diameter) line.
3. Cut trimmer line to 23 inches.
4. Stop the engine. Wait for all moving parts to stop. Disconnect spark plug wire.
5. Remove worn trimmer line.
6. Thread trimmer line through to outside holes as shown in Figure 4.
7. Bring the two ends together and insert them (from the back) through the middle hole as shown in figure 5.
8. Tighten the trimmer line as shown in Figure 6.
9. Repeat for the other side.

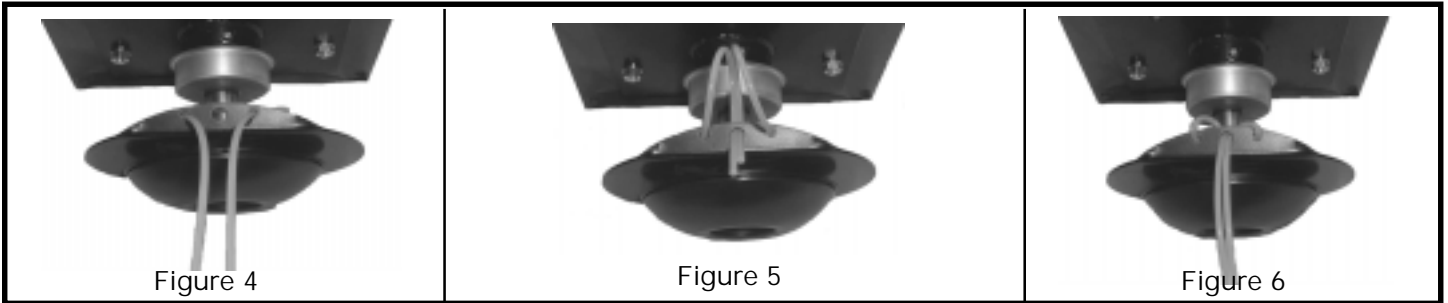

### Cut Height Adjustment

1. The cut height can be set at 1 7/8" and 3 3/4".
2. Stop the engine. Wait for all moving parts to stop. Disconnect the spark plug wire.
3. Use the allen wrench found in the parts bag to loosen the set screw shown in Figure 7.
4. Set the trimmer head at the desired height.
5. Tighten the set screw.

### Lubrication of Jackshaft

1. Stop the engine. Wait for all moving parts to stop. Disconnect the spark plug wire.
2. Use a grease gun with a good grade of automotive grease to lubricate the jackshaft using the grease fitting (See Figure 7).

### Drive Belt Adjustment

1. If the trimmer head does not turn effectively. The drive belt may have seated.
2. Stop the engine. Wait for all moving parts to stop. Disconnect the spark plug wire.
3. Observe distance between inside span of belts at the narrowest point. Span should measure 1 inch.
4. Loosen the bolts that hold the trimmer head and jackshaft to the trimmer under body (See Figure 7).
5. Move the assembly forward to tighten the belt or remove belt and replace if it is worn.
6. Tighten bolts.
7. Recheck the belt inside span.

### Maintenance Schedule

1. Before each use: Check engine oil level, Check trimmer lines, Check trimmer head engagement, Clean engine, engine bonnet and machine of excess grass and oil, Remove debris from guard, engine bonnet, and deck, and Check nuts and bolts for appropriate tightness.
2. After every 25 hours: Check spark plug, Change engine oil, Change or clean air filter, lubricate jackshaft, and lubricate wheel bearings.

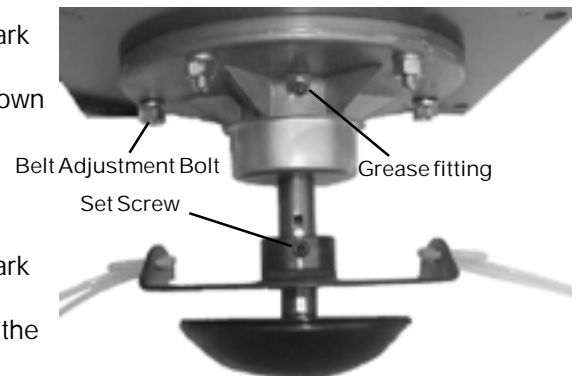

Figure 7



| Ref. No. | Part   | Description                      | Ref. No. | Part   | Description                         | Ref. No. | Part   | Description                  |
|----------|--------|----------------------------------|----------|--------|-------------------------------------|----------|--------|------------------------------|
| 1        | 358202 | Unibody -- painted               | 31       | KT1965 | 10 pack trimmer line                | 60       | 446130 | 1/4" Lock Washer             |
| 2        | 400184 | Cap screw -- 5/16 x 3/4 NC5      |          | KT1966 | 20 pack trimmer line                | 61       | 443101 | 1/4" NC Hex Nut              |
| 3        | 455041 | 5/16 flat washer                 |          | KT1967 | 80 pack trimmer line                | 62       | 400297 | Shoulder Bolt -- 3/8" x 1"   |
| 4        | 446136 | 5/16 Lock washer                 | 32       | 313794 | Glide Bowl                          | 63       | 455042 | 3/8" Flat Washer             |
| 5        | 443106 | 5/16" NC hex Nut                 | 33       | 455045 | Fender Washer -- 3/8" x 1 1/2"      | 64       | 444716 | 5/16" NC Centerlock Nut      |
| 6        | 358205 | Belt guide -- painted            | 34       | 463018 | Key -- 3/16" x 1/2"                 | 65       | 336779 | Decal -- Caution             |
| 7        | 336667 | pulley, 3-1/2" x 7/8"            | 35       | 463012 | Key -- 3/16" x 2"                   | 66       | 336720 | Decal -- Do not operate      |
| 8        | 415562 | Set Screw -- 5/16-18 x 5/16"     | 36       | 336670 | Pulley -- 3 1/2" x 5/8"             | 67       | 336790 | Decal -- Engage Blad Control |
| 9        | 359383 | Key -- 3/16" x 1"                | 37       | 455062 | Shim Washer -- 41/64" x 1" x .032   | 68       | 336938 | Decal -- Danger Keep Hands   |
| 10       | 132126 | Engine                           | 38       | 358201 | Hub Belt Guide -- Painted           | 69       | 336792 | Decal -- 24"                 |
| 11       | 400200 | Cap Screw -- 5/16" x 2 1/2" NC5  | 39       | 358203 | L.H. Wheel Bracket -- painted       | 70       | 336761 | Decal -- Maxim               |
| 12       | 400194 | Cap Screw -- 5/16" x 1 1/2" NC5  | 40       | 358204 | R.H. Wheel Bracket -- painted       | 71       | 336924 | Decal -- Made in the USA     |
| 13       | 359559 | Cable Holder                     | 41       | 358219 | Bottom Cover -- Painted             | 132119-A |        | Bonnet guard                 |
| 14       | 162055 | Capro Control                    | 42       | 408883 | 1/4" x 1/2" Hex Washer Screw        | 132119-B |        | Foam Bonnet                  |
| 15       | 358213 | Idler Arm Assembly -- painted    | 43       | 359360 | S-Hook                              | 132119-C |        | O Ring                       |
| 16       | 359321 | Idler Pulley -- 2 3/4" x 3/8"    | 44       | 358212 | Drag Shield -- Painted              | KT1972   |        | Engine Bonnet Kit            |
| 17       | 400290 | Cap Screw -- 3/8" x 1 3/4" NC2   | 45       | 359349 | 3/4" Cap Plug                       |          |        |                              |
| 18       | 444721 | 3/8" NC Center lock Nut          | 46       | 130700 | Wheel -- 14" Plastic Yellow         |          |        |                              |
| 19       | 359344 | Shoulder Bolt -- 1/2" x 1 7/8"   | 47       | 400294 | Shoulder Bolt -- 3/8" x 1/2" x 2.50 |          |        |                              |
| 20       | 455044 | 1/2" Flat Washer, STD            | 48       | 358206 | LH Brace-- Top Shield -- Painted    |          |        |                              |
| 21       | 272254 | Belt -- L448                     | 49       | 358207 | RH Brace -- Top Shield -- Painted   |          |        |                              |
| 22       | 359369 | Extension Spring                 | 50       | 358208 | Top Shield                          |          |        |                              |
| 23       | 358220 | Hub Plate -- painted             | 51       | 358210 | Lower Handle -- Painted             |          |        |                              |
| 24       | 400190 | Cap Screw -- 5/16" x 1 1/4" NC5  | 52       | 358211 | Upper Handle -- Painted             |          |        |                              |
| 25       | 400186 | Cap Screw -- 5/16" x 1" NC5      | 53       | 360106 | Knob -- 5/16"                       |          |        |                              |
| 26       | 162011 | Hub Asembly                      | 54       | 162046 | Throttle Control                    |          |        |                              |
| 27       | 358218 | Dust Cup -- Spot Weld            | 55       | 358221 | Control Lever Stop Bracket          |          |        |                              |
| 28       | 358216 | Cutter Head                      | 56       | 400219 | Pull Rope Guide                     |          |        |                              |
| 29       | 131103 | Shaft. Hub                       | 57       | 445768 | 1/4" hex Nut                        |          |        |                              |
| 30       | 358209 | Support Washer, Glide -- painted | 58       | 130623 | Trimmer control Lever               |          |        |                              |
| 31       | 358217 | Trimmer Line-- 23"               | 59       | 400116 | Cap Screw -- 1/4" x 2" NC5          |          |        |                              |

## Limited Warranty

Maxim Manufacturing Corporation, through its dealers will repair or replace any part, or parts of the Trimmer frame or handles that are defective in material or workmanship or both. Transportation charges on parts submitted for repair or replacement under this Warranty must be borne by purchaser. The original sales receipt must be submitted as proof of purchase date. The sales receipt will be returned. Maxim Manufacturing Corporation assumes no liability for labor charges made in performance of this warranty.

The Warranty periods are as follows:

- A. Frame for 1 Year
- B. Handles for 1 Year

The Throttle Cable, Tires, Fasteners, trimmer cord and belt are not warranted because during normal service they are subject to wear.

The Warranty on the Frame is Void if:

- A. Frame is broken or bent due to abuse.
- B. Wheels are bent or broken due to impact.
- C. Altering of engine or its components has occurred.

All warranties are voided if the Trimmer has been altered, rented, used under abnormal conditions, or subject to abuse, misuse, neglect, or improper maintenance.

The Engine is warranted by the engine manufacturer, not by Maxim Manufacturing Corporation. See Engine Owner's Manual for information regarding engine warranty.

Should you experience problems with your Trimmer take it back to your authorized Maxim dealer or distributor to make warranty claims.

Maxim Manufacturing is not liable for any damage claim or liability claim, personal or otherwise, resulting from the operation of this vehicle in any way.